



UNIVERSITY OF CAMBRIDGE INTERNATIONAL EXAMINATIONS
International General Certificate of Secondary Education

CANDIDATE
NAME

CENTRE
NUMBER

--	--	--	--	--

CANDIDATE
NUMBER

--	--	--	--



CHEMISTRY

0620/21

Paper 2

May/June 2011

1 hour 15 minutes

Candidates answer on the Question Paper.

No Additional Materials are required.

READ THESE INSTRUCTIONS FIRST

Write your Centre number, candidate number and name in the spaces at the top of this page.

Write in dark blue or black pen.

You may need to use a pencil for any diagrams, graphs or rough working.

Do not use staples, paper clips, highlighters, glue or correction fluid.

DO NOT WRITE IN ANY BARCODES.

Answer **all** questions.

A copy of the Periodic Table is printed on page 16.

At the end of the examination, fasten all your work securely together.

The number of marks is given in brackets [] at the end of each question or part question.

For Examiner's Use	
1	
2	
3	
4	
5	
6	
7	
8	
Total	

This document consists of **15** printed pages and **1** blank page.



1 The structures of some substances containing nitrogen are shown below.

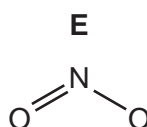
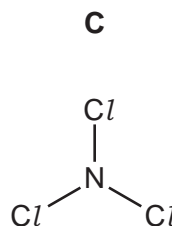
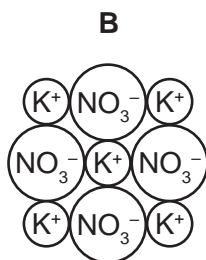
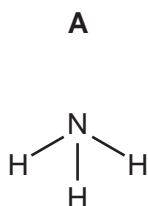

Answer the following questions by choosing from the structures **A**, **B**, **C**, **D** or **E**.
You can use each structure once, more than once or not at all.

Which structure represents

- | | |
|--|--------------------------|
| (a) an acidic oxide, | <input type="checkbox"/> |
| (b) an ionic giant structure, | <input type="checkbox"/> |
| (c) a gas which turns moist litmus paper blue, | <input type="checkbox"/> |
| (d) a compound which is formed under conditions of high temperature and pressure in car engines, | <input type="checkbox"/> |
| (e) a molecule containing halogen atoms, | <input type="checkbox"/> |
| (f) a salt? | <input type="checkbox"/> |

[Total: 6]

2 Vanadium has two isotopes.



(a) Define the term *isotope*.

.....
 [1]

(b) An atom contains protons, electrons and neutrons.
 Complete the table to show the number of protons, electrons and neutrons in these two isotopes of vanadium.

isotope	number of protons	number of electrons	number of neutrons
${}_{23}^{50}\text{V}$	23	23	
${}_{23}^{51}\text{V}$			28

[3]

(c) Complete these sentences using words from the list.

cancer extra industry influenza medicine non

Two types of isotopes are radioactive and-radioactive. Radioactive isotopes are used in for treating patients with [3]

(d) Vanadium is a transition element.
 Which two of these statements about vanadium are correct?
 Tick **two** boxes.

- vanadium is a non-metal
- vanadium conducts electricity
- vanadium has a low melting point
- vanadium is less dense than sodium
- compounds of vanadium are coloured

[2]

[Total: 9]

3 Water is present in the atmosphere, the seas and in ice and snow.

(a) Describe a chemical test for water.

test

result [2]

(b) State **one** use of water in industry.

..... [1]

(c) Water is a good solvent.

What do you understand by the term *solvent*?

..... [1]

(d) Water vapour in the atmosphere reacts with sulfur dioxide, SO₂, to produce acid rain.

(i) State **one** source of sulfur dioxide.

..... [1]

(ii) State **two** adverse effects of acid rain.

1.

2. [2]

(iii) Calculate the relative molecular mass of sulfur dioxide.

[1]

(e) Water from lakes and rivers can be treated to make the water safer to drink.

Describe **two** of the steps in water purification.

For each of these steps, give an explanation of its purpose.

step 1

.....

step 2

..... [4]

(f) Water is formed when hydrogen burns in air.

(i) State the percentage of oxygen present in the air.

..... [1]

(ii) When 8 g of hydrogen is burned in excess air, 72 g of water is formed.
What mass of hydrogen needs to be burnt to produce 252 g of water?

[1]

[Total: 14]

4 The structures of some organic compounds are shown below.

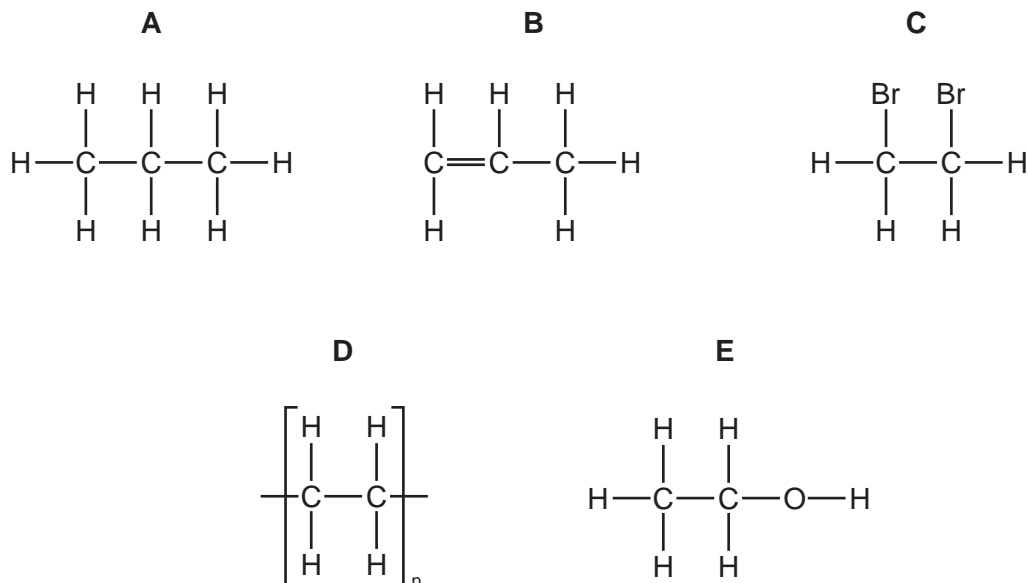

(a) Which one of these structures represents

- (i) a polymer,
- (ii) an unsaturated hydrocarbon,
- (iii) the product of the catalytic addition of steam to ethene,
- (iv) a product of the addition of aqueous bromine to ethene?

[4]

(b) (i) Balance the equation for the complete combustion of compound **A**, C_3H_8 .

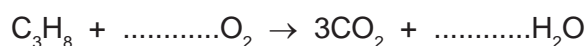

[2]

(ii) State the name of **two** substances formed when compound **A** undergoes incomplete combustion.

..... and [2]

(c) Complete the structure of ethanoic acid to show all atoms and bonds.

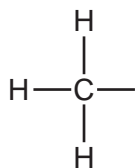

[1]

[Total: 9]

- 5 Concentrated hydrochloric acid can be electrolysed using the apparatus shown.

For
Examiner's
Use

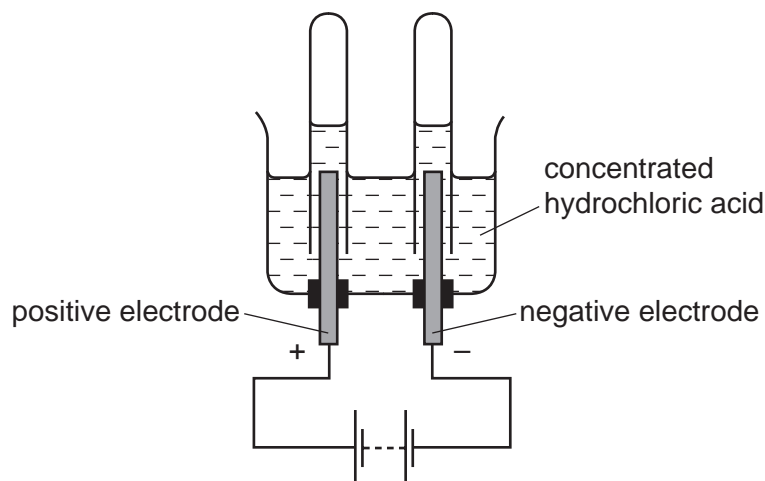

- (a) What do you understand by the term *electrolysis*?

.....
 [1]

- (b) What is the name given to the positive electrode?
 Put a ring around the correct answer.

anion **anode** **cathode** **cation** **electrolyte** [1]

- (c) State the name of the gas given off at the negative electrode.

..... [1]

- (d) Complete the following sentence about electrolysis using words from the list.

inert **magnesium** **platinum** **reactive** **solid**

Electrodes made of graphite or are generally used in electrolysis
 because they are [2]

(e) When concentrated hydrochloric acid is electrolysed, chlorine is released at the positive electrode.

(i) Draw the arrangement of the electrons in an atom of chlorine.

[1]

(ii) Draw the electronic structure of a chlorine molecule.
Show only the outer electron shells.

[2]

(iii) Describe a test for chlorine.

test

result [2]

(f) Hydrochloric acid reacts with the base calcium hydroxide.

(i) Complete the word equation for this reaction.

hydrochloric acid + calcium hydroxide → +
.....

[2]

(ii) Hydrochloric acid also reacts with zinc.
Complete the symbol equation for this reaction.

$$\text{Zn} + \dots\dots\dots\text{HCl} \rightarrow \text{ZnCl}_2 + \dots\dots\dots$$

[2]

[Total: 14]

6 A student observed the reaction of various metals with both cold water and steam. Her results are shown below.

metal	reaction with cold water	reaction with steam
calcium	reacts rapidly	reacts very rapidly
copper	no reaction	no reaction
magnesium	reacts very slowly	reacts rapidly
zinc	no reaction	reacts

(a) (i) Put these metals in order of their reactivity.

least reactive \longrightarrow most reactive

--	--	--	--

[1]

(ii) Iron is a metal between zinc and copper in the reactivity series. Predict the reactivity of iron with

cold water,

steam. [2]

(b) The equation for the reaction of zinc with steam is:

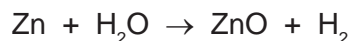

Write a word equation for this reaction.

[1]

(c) State **three** physical properties which are characteristic of **most** metals.

1.

2.

3. [3]

(d) Some properties of the Group I metals are shown in the table.

metal	melting point /°C	hardness	density /g per cm ³
lithium		fairly hard	0.53
sodium	98	fairly soft	
potassium	63	soft	
rubidium	39	very soft	1.53
caesium	29	extremely soft	1.88

(i) Estimate the melting point of lithium.

..... [1]

(ii) How does the hardness of these metals change down the group?

..... [1]

(iii) Estimate the density of potassium.

..... [1]

[Total: 10]

- 7 The diagram shows a basic oxygen converter. This is used to convert impure iron from the blast furnace into steel. During this process, some of the impurities in the iron are converted into a slag.

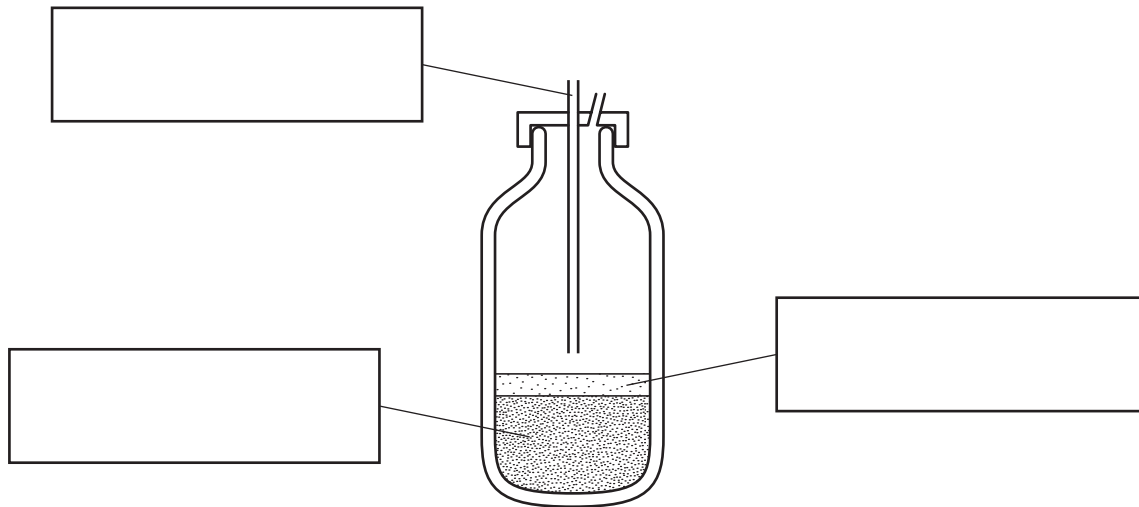

(a) Label the diagram to show each of the following:

- where the oxygen enters;
- the slag;
- the molten steel.

[3]

(b) In the converter, the oxygen oxidises sulfur, carbon and phosphorus to their oxides.

- (i) Explain why sulfur dioxide and carbon dioxide are easily removed from the converter.

..... [1]

- (ii) Explain how calcium oxide is used to remove phosphorus(V) oxide from the converter.

.....

 [3]

(c) Stainless steel is an alloy.

- (i) Which **one** of the diagrams, **A**, **B**, **C** or **D**, best represents an alloy?
Put a ring around the correct answer.

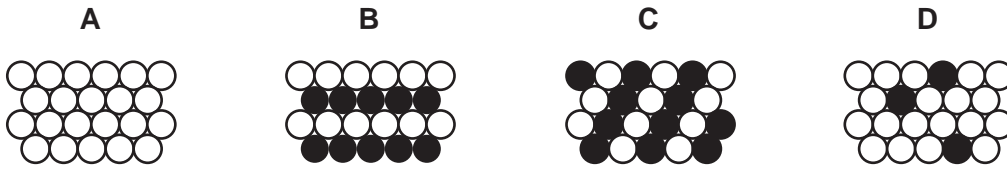

[1]

- (ii) State **one** use of stainless steel.

..... [1]

[Total: 9]

8 Bromine is a red-brown liquid. When warmed, it forms an orange vapour.

- (a) Describe what happens to the arrangement and motion of the particles when bromine changes state from a liquid to a vapour.

.....

 [3]

(b) Bromine can be obtained from bromide ions in seawater.

- (i) The symbol equation for this reaction is:

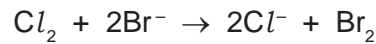

Complete the word equation for this reaction.

..... + bromide ions \rightarrow + [1]

- (ii) Bromine is very volatile, so it can be removed from solution by bubbling air through the solution.

What do you understand by the term *volatile*?

..... [1]

(c) Hydrogen reacts with bromine in the presence of a hot platinum catalyst to form hydrogen bromide.

- (i) Define the term *catalyst*.

..... [1]

- (ii) Hydrogen bromide reduces hydrogen peroxide, H_2O_2 .

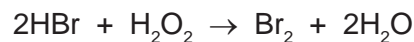

Explain how this equation shows that hydrogen peroxide is reduced.

.....
 [1]

- (iii) A solution of hydrogen bromide in water is called hydrobromic acid. Hydrobromic acid has similar reactions to hydrochloric acid.

State the names of **three** products formed when hydrobromic acid reacts with sodium carbonate.

..... [2]

[Total: 9]

DATA SHEET
The Periodic Table of the Elements

		Group												
I	II	III	IV	V	VI	VII	0							
		1 H Hydrogen 1					4 He Helium 2							
7 Li Lithium 3	9 Be Beryllium 4		11 B Boron 5	12 C Carbon 6	13 Al Aluminium 13	14 Si Silicon 14	15 P Phosphorus 15	16 S Sulfur 16	17 Cl Chlorine 17	18 Ar Argon 18	19 F Fluorine 9	20 Ne Neon 10		
23 Na Sodium 11	24 Mg Magnesium 12		27 Al Aluminium 13	28 Si Silicon 14	29 Co Cobalt 27	30 Zn Zinc 30	31 Ga Gallium 31	32 Ge Germanium 32	33 As Arsenic 33	34 Se Selenium 34	35 Br Bromine 35	36 Kr Krypton 36		
39 K Potassium 19	40 Ca Calcium 20		48 Ti Titanium 22	51 V Vanadium 23	55 Mn Manganese 25	56 Fe Iron 26	59 Ni Nickel 28	64 Cu Copper 29	65 Zn Zinc 30	70 Ga Gallium 31	73 Ge Germanium 32	75 As Arsenic 33	79 Se Selenium 34	84 Kr Krypton 36
85 Rb Rubidium 37	88 Sr Strontium 38		91 Zr Zirconium 40	93 Nb Niobium 41	96 Mo Molybdenum 42	101 Ru Ruthenium 44	103 Rh Rhodium 45	106 Pd Palladium 46	108 Ag Silver 47	112 Cd Cadmium 48	115 In Indium 49	122 Sb Antimony 51	128 Te Tellurium 52	131 Xe Xenon 54
133 Cs Caesium 55	137 Ba Barium 56		178 Hf Hafnium 72	181 Ta Tantalum 73	184 W Tungsten 74	190 Os Osmium 76	192 Ir Iridium 77	195 Pt Platinum 78	197 Au Gold 79	201 Hg Mercury 80	204 Tl Thallium 81	209 Pb Lead 82	210 Po Polonium 84	210 Rn Radon 86
87 Fr Francium	88 Ra Radium	89 Ac Actinium												

140 Ce Cerium 58	141 Pr Praseodymium 59	144 Nd Neodymium 60	150 Sm Samarium 62	152 Eu Europium 63	157 Gd Gadolinium 64	162 Dy Dysprosium 66	165 Ho Holmium 67	167 Er Erbium 68	169 Tm Thulium 69	173 Yb Ytterbium 70	175 Lu Lutetium 71		
232 Th Thorium 90	238 U Uranium 92	238 Pa Protactinium 91	238 Np Neptunium 93	238 Pu Plutonium 94	238 Am Americium 95	238 Cm Curium 96	238 Bk Berkelium 97	238 Cf Californium 98	238 Es Einsteinium 99	238 Fm Fermium 100	238 Md Mendelevium 101	238 No Nobelium 102	238 Lr Lawrencium 103

a	X	b
---	----------	---

Key
 a = relative atomic mass
 X = atomic symbol
 b = proton (atomic) number

*58-71 Lanthanoid series
 †90-103 Actinoid series

The volume of one mole of any gas is 24 dm³ at room temperature and pressure (r.t.p.).

Permission to reproduce items where third-party owned material protected by copyright is included has been sought and cleared where possible. Every reasonable effort has been made by the publisher (UCLES) to trace copyright holders, but if any items requiring clearance have unwittingly been included the publisher will be pleased to make amends at the earliest possible opportunity.

University of Cambridge International Examinations is part of the Cambridge Assessment Group. Cambridge Assessment is the brand name of University of Cambridge Local Examinations Syndicate (UCLES), which is itself a department of the University of Cambridge.